

Installation Instructions

Read these instructions thoroughly before starting

PILOT/THERMOPILE ASSEMBLY

Kit Contents: Pilot/Thermopile Assembly, Pilot Tube, & Ferrule Nut.

Tools Required: needle nose pliers, 7/16" open-end wrench, 3/4" open-end wrench, 1/4" nut driver, Phillips head screwdriver, flat-blade screwdriver, approved noncorrosive leak-detection solution.

Important: For correct water heater operation, it is essential that the pilot/thermopile assembly be properly installed. If you lack the necessary skills to properly perform the installation, you should not proceed, but get help from a qualified person.

Removing the Burner/Manifold Assembly and the Pilot/Thermopile Assembly

Important: DO NOT operate the water heater without the orifice installed.

1. Before performing any maintenance, it is important to turn off the main gas supply to the water heater at the manual gas shut-off valve. This valve is typically located beside the water heater. Note the position of the shut-off valve in the open/on position then proceed to turn it off (see Figure 1).

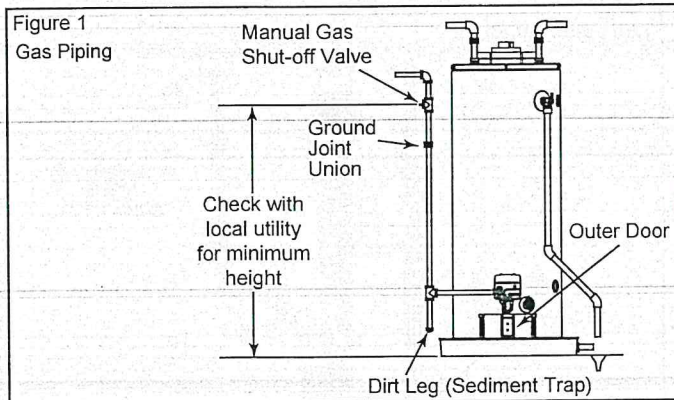

2. Set the gas control valve/thermostat knob to the "OFF" position (see Figure 2).
3. With the unit shut-off allow sufficient time for the water heater to cool before performing any maintenance.
4. Remove the outer door (see Figure 1).
5. Disconnect the igniter wire from the igniter lead wire and, using needle nose pliers, disconnect the thermopile wires connector from the gas control valve/thermostat (see Figure 2).
6. Use a 7/16" open-end wrench to disconnect the pilot tube from the gas control valve/thermostat by turning clockwise. Use a 3/4" open-end wrench to disconnect the manifold tube from the gas control valve/thermostat by turning clockwise for natural gas (counterclockwise for LP gas) (see Figure 2).

Figure 2

Gas Control Valve/
Thermostat

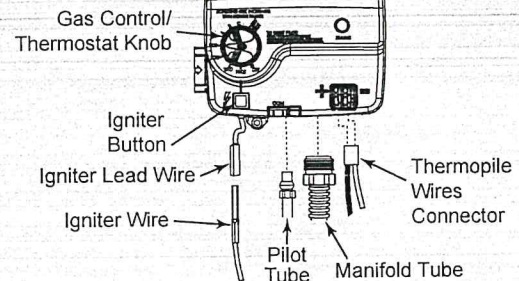

7. Grasp each of the tubes and push down slightly to free the manifold tube and pilot tube.
8. Use a 1/4" nut driver to remove the screws on both sides of the burner/manifold door assembly that secure the assembly to the combustion chamber. Retain the screws to reinstall the burner/manifold door assembly from the combustion chamber. BE SURE NOT TO DAMAGE ANY INTERNAL PARTS.
9. The burner must be removed to access the pilot/thermopile assembly. Use a Phillips head screwdriver to remove the 2 screws securing the burner to the manifold. Be sure to retain the screws to reinstall the burner later (see Figure 3).

Important: DO NOT remove the orifice.

Figure 3

Manifold/Burner
Assembly (Natural
and LP Gas
Models; See also
Fig. 4)

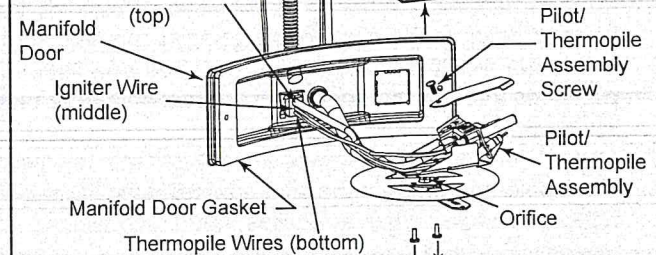

10. Use a Phillips head screwdriver to remove the screw securing the pilot/thermopile assembly to the pilot bracket. Retain the screw for reuse to reinstall the pilot/thermopile assembly later (see Figure 3).

- Use a flat-blade screwdriver to lift the retainer clip straight up from the back of the manifold component block, then remove the manifold component block from the manifold door (see Figure 4). Be sure to keep the retainer clip for use in reinstalling manifold component block later.

Important: Be careful not to bend or alter the position of the pilot tube, it will be used as a bending template for the new pilot assembly. Note the placement/order of the wires in the manifold component block.

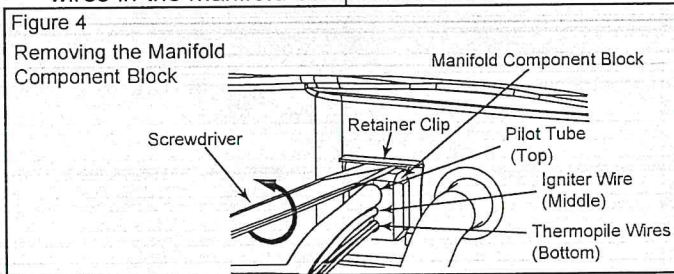

- Remove the pilot/thermopile assembly from the burner assembly by pulling it thru toward the burner side of the manifold door assembly. Lift the pilot/thermopile assembly (including the igniter wire) from the manifold/burner assembly (see Figure 5).

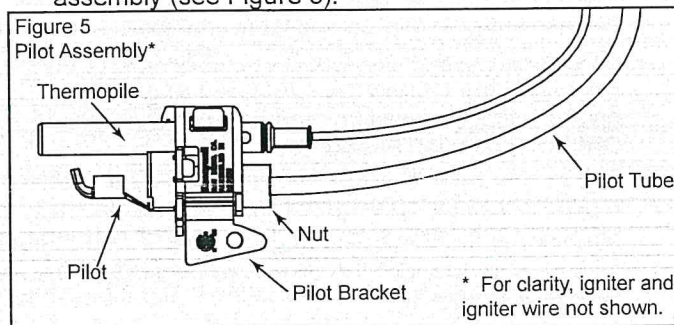

Installing the Pilot/Thermopile Assembly and the Burner/Manifold Assembly

Note: Read the next step carefully before proceeding. Ensure you do not kink the pilot tube when making the bends.

- Using the old pilot/pilot tube assembly as a guide, bend the new pilot tube to match the old one. Make only the bends closest to the pilot before going to the next step.
- Route the new pilot tube, igniter wire and new thermopile wires through the opening in the manifold door (see Figure 3).
- Use a Phillips head screwdriver to reattach the pilot/thermopile assembly to the pilot bracket using the screw removed earlier. Use a Phillips head screwdriver to reattach the burner to the manifold using the 2 screws removed earlier. Ensure the burner is properly aligned on the manifold. See Figure 6 for correct orientation.
- Reinstall the manifold component block in the manifold door. Make sure that you route the pilot tube, the igniter wire, and the thermopile wires through the correct openings in the manifold component block (see Figures 4 & 7). Once the pilot tube, igniter wire and thermopile wires are properly installed in the manifold component block secure the manifold component block with the retainer clip removed earlier.

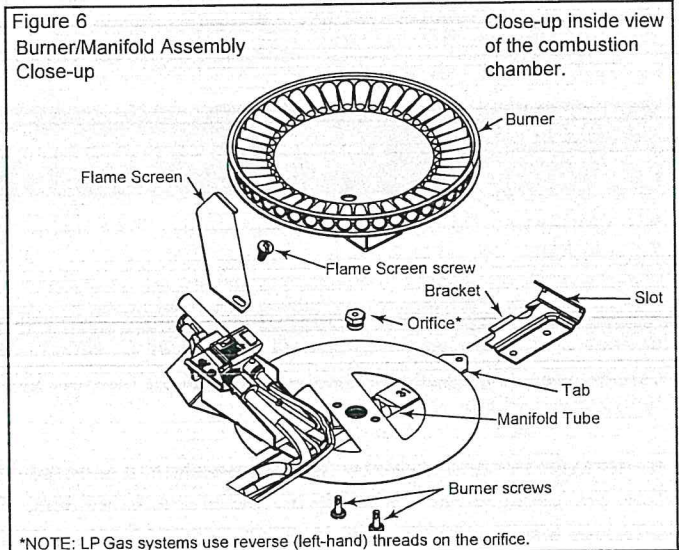

- Carefully bend the new pilot tube to match the bend of the manifold tube.
Note: When bending DO NOT crimp or crease the pilot tube.
- Check the burner/manifold assembly's door gasket for damage or imbedded debris prior to installation (see Figure 3).
- Insert the burner/manifold assembly into the burner compartment making sure the tab of the manifold tube engages the slot in the bracket inside the combustion chamber (see Figure 6). Make sure not to damage any parts when installing the burner/manifold assembly.

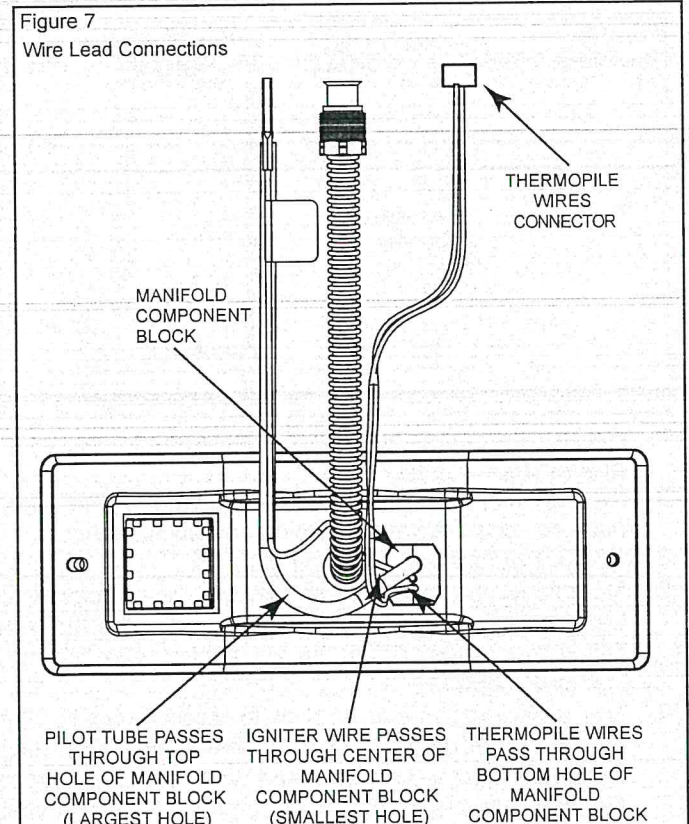

8. Inspect the door gasket and make sure no fiberglass insulation or other debris is between the manifold door gasket and the combustion chamber.
9. Use a 1/4" nut driver to tighten the two screws which secure the burner/manifold assembly to the combustion chamber. There should be no space between the gasket of the manifold door and combustion chamber.
Important: Do not operate the water heater if the door gasket does not create a seal between the manifold door and the combustion chamber.

⚠ WARNING

Explosion Hazard
<p>Tighten both manifold door screws securely. Remove any fiberglass between gasket and combustion chamber.</p> <p>Replace viewport if glass is missing or damaged.</p> <p>Replace manifold component block if missing or removed.</p> <p>Replace door gasket if damaged.</p> <p>Failure to do so can result in death, explosion, or fire.</p>

10. Use a 3/4" opened end wrench to reconnect the manifold tubing to the gas control valve by turning counter-clockwise for natural gas (clockwise for LP gas).
Important: Do not cross-thread these fittings. Do not apply any thread sealant to these fittings.
11. Some gas control valve/thermostats will have the ferrule nut already installed on the pilot output. If the gas valve does not have the ferrule nut already installed on the pilot output, a ferrule nut must be installed on the pilot output prior to the pilot tube being connected to the gas valve. Insert the pilot tube into the ferrule nut and ensure the tube is fully inserted into the gas control valve/thermostat. Apply upward pressure to keep the pilot tube fully seated and tighten ferrule nut with a 7/16" open-end wrench until tight on gas control valve/thermostat.
Important: Do not cross-thread these fittings. Do not apply any thread sealant to these fittings.
12. Connect the thermopile wires connector, using care not to damage the connector, to the gas control valve/thermostat (see Figure 2).
13. Reconnect the igniter wire (see Figure 2).

14. Turn the gas on at the manual gas shut-off valve and check the main gas supply and gas valve for leaks. Test the supply connections by brushing on an approved noncorrosive leak-detection solution. If such a solution is not available, use a mixture of dish washing soap and water (one part soap to 15 parts water) or children's soap bubble solution. Bubbles forming indicate a leak. Correct any leak found.
Caution: Do not spray leak detection solution on the gas control/thermostat housing or use excessive amounts. Electrical components can be damaged.

⚠ WARNING

Fire or Explosion Hazard
<p>Check for gas leaks with soap and water solution any time work is done on a gas system.</p> <p>Failure to do so can cause severe injury, death or property damage.</p>

15. Follow the "Lighting Instructions" on the heater to relight the unit. With the water heater's main burner lit, check for leaks at the manifold and pilot connections by brushing on an approved noncorrosive leak-detection solution. Bubbles will show a leak. Correct any leak found.
16. If leaks are found shut the unit off and fix the leaks. Once the leaks are fixed repeat previous step 15. If no leaks are found replace the outer door and set thermostat to desired setting.

⚠ DANGER	<p>Water temperature over 125°F (52°C) can cause severe burns instantly resulting in severe injury or death.</p> <p>Children, the elderly and the disabled and are at highest risk of scald injury.</p> <p>Feel water before bathing or showering.</p> <p>Temperature limiting devices such as mixing must be installed when required by codes and to ensure safe temperatures at fixtures.</p> <p>Read instruction manual for safe temperature setting.</p>
